

**Power-Trax.de**

Special Duty Vehicles - technical Distribution

<http://www.power-trax.de>

info @ power-trax.de

Tel.: +49 - (0)2947 / 973 858 17

Mobil: +49 - (0)163 / 4321 435

Fax: +49 - (0) 2947 / 973 858 18

Natheweg 16

DE-59609 Anroechte

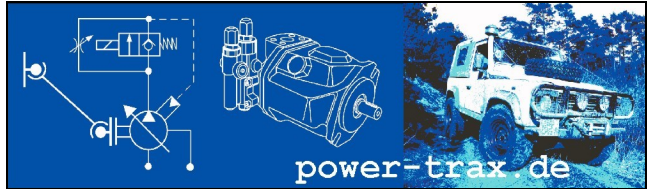

# Hydraulic Systems and Custom Solutions

for all 4x4 and utility vehicles



## 2011 Catalogue

All prices net, excl. VAT - General terms and conditions of business apply

**power-trax.de**

Special Duty Vehicles - technical Distribution

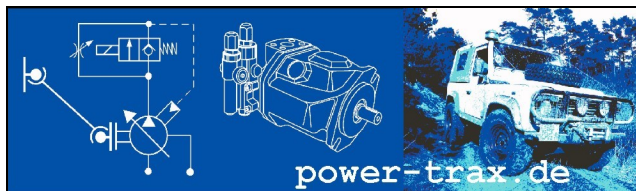

## Basics on PTO Drivetrain Concepts

Here we have some basic introduction in PTO concepts.

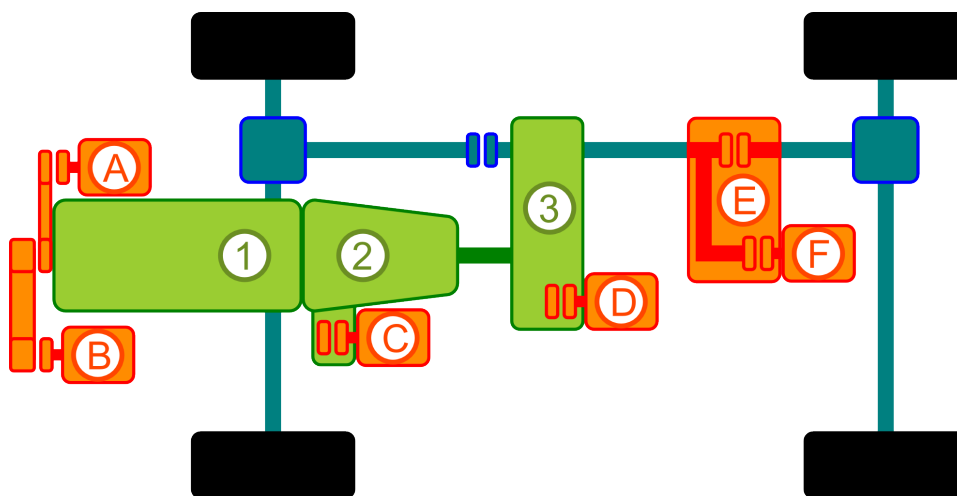

*Pic 1: PTO-Variants*  
1: Engine - 2: Gearbox - 3: Transfer Gearbox

Depending on your vehicle several variants of PTO installations are possible.

Variant	Details	Power
<b>A</b>	Belt driven PTO, electromagnetic or mechanical clutch. Uses stock belt drive. Requires mounting space at engine. PTO can partially be used during driving.	7-10kW
<b>B</b>	Tooth belt driven PTO, mechanical clutch. Requires additional belt drive. Requires extended mounting space at engine. PTO can partially be used during driving.	to 30kW
<b>C</b>	Gearbox coupled PTO, mechanical clutch. Gearbox needs to be prepared or expandable for PTO. PTO can partially be used during driving.	to 460kW
<b>D</b>	Transfer gearbox coupled PTO, mechanical clutch. Gearbox needs to be prepared or expandable for PTO. PTO can only be used stationary.	to 76kW
<b>E/F</b>	Driveshaft coupled PTO, mechanical clutch. Fits all RWD vehicles and vehicles with selectable 4WD. PTO can only be used stationary.	22 to 136kW

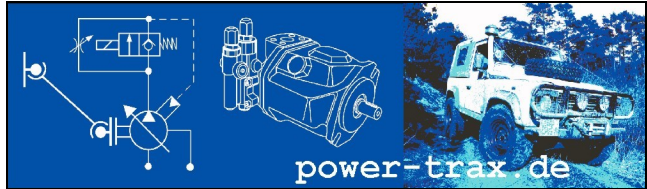

## IVECO Massif PTOs & Hydraulic Systems Crankshaft coupled (system 'C')

Complete kits fitting IVECO Massif 3.0 & Daily 4x4 as well as Bremach T-Rex with ZF gearbox.

These kits are suitable to operate dumpers, hydraulic winches, generators, compressors and all other hydraulic equipment.

We do offer a comprehensive service regarding design and integration of hydraulic systems - please get in contact with us accordingly!

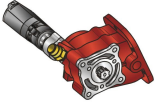
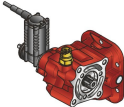
ID#	Details	Price
	<p><b>Kit IVECO Massif 3.0 / Daily 4x4 / Bremach T-Rex - 18kW</b></p> <ul style="list-style-type: none"> <li>● PTO, electronically operated</li> <li>● Pump 36ccm / 200bar / 50lpm</li> <li>● Power Control Unit</li> <li>● 1500 Upm: 50lpm / 18.8kW</li> <li>● 3000 Upm: 100lpm / 37kW (intermittent)</li> <li>● ECU with panel</li> <li>● crankshaft coupled</li> </ul> <p>Requires tank, valves and hoses. Supports and hoses need to be modified.</p>	1230,- EUR
	<p><b>Kit IVECO Massif 3.0 / Daily 4x4 / Bremach T-Rex - 29kW</b></p> <ul style="list-style-type: none"> <li>● PTO, electronically operated</li> <li>● Pump 57ccm / 200bar</li> <li>● Power Control Unit</li> <li>● 1500 Upm: 80lpm / 29.4kW</li> <li>● 3000 Upm: 160lpm / 58kW (intermittent)</li> <li>● ECU with panel</li> <li>● crankshaft coupled</li> </ul> <p>Requires tank, valves and hoses. Supports and hoses need to be modified.</p>	1310,- EUR

**Power-Trax.de**

Special Duty Vehicles - technical Distribution

<http://www.power-trax.de>

info @ power-trax.de

Tel.: +49 - (0)2947 / 973 858 17

Mobil: +49 - (0)163 / 4321 435

Fax: +49 - (0) 2947 / 973 858 18

Hauptstrasse 81

DE-59609 Anroechte

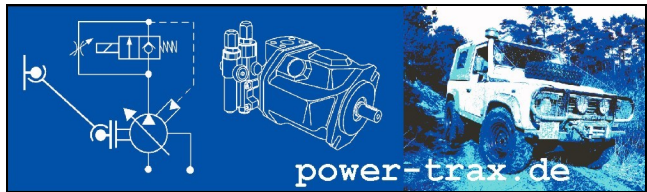

## Landrover Defender & IVECO Massif PTOs & Hydraulic Systems - Gearbox coupled (system 'D')

PTO-hydraulic-systems for LandRover Defender 90 and 110, IVECO Massif and Daily 4x4 plus Santana PS-10. Fits LT230-transfercase.

These kits are suitable to operate dumpers, hydraulic winches, generators, compressors and all other hydraulic equipment.

We do offer a comprehensive service regarding design and integration of hydraulic systems - please get in contact with us accordingly!

ID#	Details	Price
	<p><b>PTO 38kW and 30kW - air or manual operated clutch</b></p> <ul style="list-style-type: none"> <li>● <b>air operated PTO clutch - convenient installation!</b></li> <li>● manual operation available</li> <li>● Gearbox coupled - fits LT230-transfer</li> <li>● rotation enginewise: 38,2kW @ 1000 RPM, axis inline</li> <li>● rotation anti-enginewise: 30,5kW @ 1000 RPM, ~85mm axis offset, Ratio 1.5x</li> <li>● flanges ISO 4-bolt and UNI (SAE per request)</li> <li>● driveshaft flange also available</li> <li>● max. 2000 RPM, thus doubling the output power!</li> </ul> <p>Requires tank, valves and hoses. May require modification of exhaust support. 9- oder 18-splined gearbox shaft required!</p>	
<b>L/R-CCW-ISO</b>	PTO 38,2kW ISO 4-bolt, 1x	888,- EUR
<b>L/R-CCW-UNI</b>	PTO 38,2kW UNI, 1x	995,- EUR
<b>L/R-CW-ISO</b>	PTO 30,5kW ISO 4-bolt, 1.2x	1220,- EUR
<b>L/R-CW-UNI</b>	PTO 30,5kW UNI, 1.2x	1322,- EUR
	Splined shaft, requires hand-in of original good part	540,- EUR

All prices net, excl. VAT - General terms and conditions of business apply

**power-trax.de**

Special Duty Vehicles - technical Distribution

**Power-Trax.de**

Special Duty Vehicles - technical Distribution

<http://www.power-trax.de>

info @ power-trax.de

Tel.: +49 - (0)2947 / 973 858 17

Mobil: +49 - (0)163 / 4321 435

Fax: +49 - (0) 2947 / 973 858 18

Hauptstrasse 81

DE-59609 Anroechte

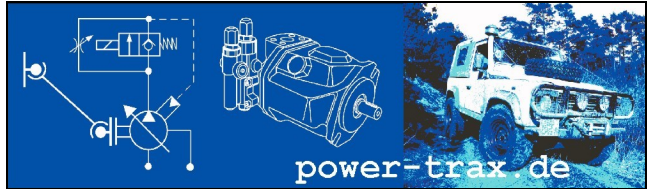

## Toyota LandCruiser Hydraulic Systems (System 'D')

Basis-Sets für Toyota LandCruiser, bestehend aus PTO, Pumpe und Betätigung.

These kits are suitable to operate dumpers, hydraulic winches, generators, compressors and all other hydraulic equipment.

We do offer a comprehensive service regarding design and integration of hydraulic systems - please get in contact with us accordingly!

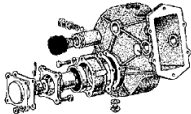
ID#	Details	Price
<b>L/C 100kW</b> 	<b>Kit Toyota LandCruiser J7/V8 Diesel manual transmission 100kW</b> <ul style="list-style-type: none"> <li>● Pump 200bar / 170lpm</li> <li>● PTO</li> <li>● air-operated clutch</li> <li>● gearbox coupled</li> </ul> <p>Requires tank, valves and hoses.</p>	*POR*
<b>L/C 29kW</b> 	<b>Basic Set Toyota LandCruiser 29kW</b> <ul style="list-style-type: none"> <li>● Special pump 210bar / 90lpm</li> <li>● driveshaft</li> <li>● frame mount</li> <li>● PTO flange</li> <li>● gearbox coupled</li> </ul> <p>Requires tank, valves and hoses and vehicle-specific PTO.</p>	1490,- EUR

All prices net, excl. VAT - General terms and conditions of business apply

**power-trax.de**

Special Duty Vehicles - technical Distribution

**Power-Trax.de**

Special Duty Vehicles - technical Distribution

<http://www.power-trax.de>

info @ power-trax.de

Tel.: +49 - (0)2947 / 973 858 17

Mobil: +49 - (0)163 / 4321 435

Fax: +49 - (0) 2947 / 973 858 18

Hauptstrasse 81

DE-59609 Anroechte

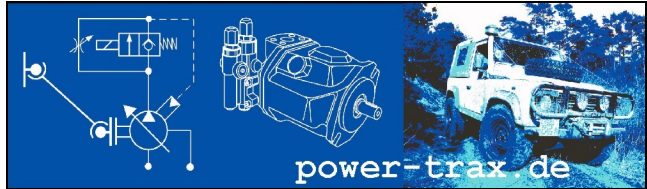

## Truck PTOs and Hydraulic Systems

Of course we are also able to supply a full range of PTOs and hydraulic pumps and systems suitable for all major brands of medium and heavy trucks and truck gearboxes:

	Details
<b>Vehicle or Gearbox brand</b>	<ul style="list-style-type: none"> <li>● Mercedes-Benz</li> <li>● IVECO</li> <li>● Volvo</li> <li>● Scania</li> <li>● Renault</li> <li>● DAF</li> <li>● ZF</li> <li>● Allison</li> <li>● Aisin</li> <li>● Turner, Spicer, DANA, New Process</li> <li>● EATON-HEMA, EATON-FULLER</li> <li>● Bedford-Leyland</li> <li>● Isuzu, Isuzu-Hino</li> <li>● Mitsubishi-Hyundai</li> <li>● Kia, Mazda, Daewoo, Daihatsu, Toyota</li> <li>● FIAT</li> <li>● International (IHC)</li> <li>● MACK</li> <li>● Kamaz - URAL - MAT</li> <li>● 'Universal' Split PTO</li> </ul>
<b>Nebenantrieb</b>	<ul style="list-style-type: none"> <li>● Single output</li> <li>● Dual or multiple output</li> <li>● different drive ratios</li> <li>● pump or shaft mounts</li> <li>● Driveshaft PTO split-gearboxes - suitable for vehicles w/o PTO-opening</li> <li>● operated electrically, manual or pneumatic</li> <li>● relocating gearboxes</li> <li>● Crankshaft coupled up to 2 x 230kW output!</li> </ul>
<b>Hydraulikpumpen</b>	<ul style="list-style-type: none"> <li>● gear pumps</li> <li>● axial- and radial-piston pumps</li> <li>● variable pumps</li> <li>● electronically controlled pumps</li> <li>● multiple pumps</li> </ul>



Please contact us with full information regarding application, vehicle, engine and gearbox type and manufacturer.

All prices net, excl. VAT - General terms and conditions of business apply

**power-trax.de**

Special Duty Vehicles - technical Distribution

**Power-Trax.de**

Special Duty Vehicles - technical Distribution

<http://www.power-trax.de>

info @ power-trax.de

Tel.: +49 - (0)2947 / 973 858 17

Mobil: +49 - (0)163 / 4321 435

Fax: +49 - (0) 2947 / 973 858 18

Hauptstrasse 81

DE-59609 Anroechte

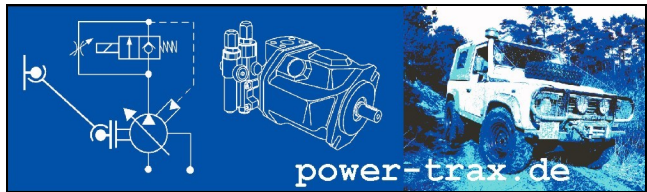

## **DYNA-PAX universal Hydraulik Pumps for light trucks and 4x4 (System A/B)**

For light trucks, 4x4, SUVs and Pickups we did develop a line of modular configurable, crankshaft-driven power blocks named DYNA-PAX®. These units offer hydraulic or pneumatic power for almost any vehicle.

	<b>Details</b>
<b>Vehicles (selection)</b>	<ul style="list-style-type: none"> <li>● Mercedes-Benz               <ul style="list-style-type: none"> <li>○ G- and GL-4x4 and SUVs</li> <li>○ ML-Klasse</li> </ul> </li> <li>● Toyota               <ul style="list-style-type: none"> <li>○ HiLux</li> <li>○ LandCruiser</li> <li>○ RAV-4</li> </ul> </li> <li>● Mitsubishi               <ul style="list-style-type: none"> <li>○ L200, Pickup</li> <li>○ Pajero</li> </ul> </li> <li>● Jeep</li> <li>● Ford               <ul style="list-style-type: none"> <li>○ F-Series</li> <li>○ Explorer</li> </ul> </li> <li>● Opel / Isuzu</li> <li>● VW               <ul style="list-style-type: none"> <li>○ Taro, T4 etc.</li> </ul> </li> <li>● Suzuki               <ul style="list-style-type: none"> <li>○ Jimny, Samurai, Vitara</li> </ul> </li> </ul>
<b>Hydraulics and energy systems</b>	<ul style="list-style-type: none"> <li>● Crankshaft synchronous operation</li> <li>● gear pumps</li> <li>● compressors</li> <li>● magnetic / electrical clutches</li> <li>● mechanical clutches</li> <li>● direct drive</li> </ul>

To set up a quotation we require information regarding vehicle, type, engine and gearbox and system requirements.

All prices net, excl. VAT - General terms and conditions of business apply

**power-trax.de**

Special Duty Vehicles - technical Distribution

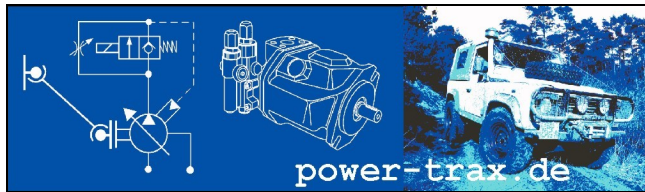

## Split-Shaft-PTOs for light, medium & heavy trucks, 4x4 and ships (System E/F)

The split shaft PTOs are available for almost all light-, medium- and heavy-duty utility vehicles, trucks , 4x4s and ships as well . They offer a whole range of variations and configurations for mobile power generation.

	Description
<b>Function</b>	<p>A Split-Shaft-PTO is an additional gearbox being fitted into the vehicle or ship. This gearbox splits the input power from the engine / main gearbox and splits it into power transferred further to the axle(s) or screw and a part being provided to the PTO(s). The gearbox mounts inbetween the existing driveshaft. Therefore the shaft is being replaced by two halves connecting to main gearbox, split-shaft-PTO-gearbox and axle(s). An integrated clutch individually operates drivetrain and PTO.</p> <p>Power classes driveshaft / PTO / connections</p> <ul style="list-style-type: none"> <li>● 2.100Nm / 250Nm - 22kW / 4fold</li> <li>● 4.000Nm / 750Nm - 71kW / 1fold</li> <li>● 8.000Nm / 1.300Nm - 136kW / 2fold</li> <li>● 20.000Nm / 1.300Nm - 136kW / 2fold &amp; 4fold</li> <li>● 24.000Nm / 1.300Nm - 110kW / 2+1fold</li> </ul> <p>PTO-connections</p> <ul style="list-style-type: none"> <li>● pump or driveshaft flange</li> <li>● various oriented power outlets, multiple outlets &amp; combinations</li> </ul> <p>Operation</p> <ul style="list-style-type: none"> <li>● pneumatically or mechanically</li> </ul> <p>Vehicles</p> <ul style="list-style-type: none"> <li>● RWD with propshaft</li> <li>● AWD / 4x4 with rear propshaft and selectable 4x4 or 6x6 (not applicable for permanent-4x4-vehicles and stationary applications)</li> <li>● Ships with shaft-driven screw</li> </ul>
<b>Sample Vehicles</b>	<ul style="list-style-type: none"> <li>● Mercedes-Benz <ul style="list-style-type: none"> <li>○ G- and GL-4x4s</li> <li>○ Trucks (Actros, Axor, Atego etc.)</li> <li>○ Sprinter</li> </ul> </li> <li>● Toyota HiLux, LandCruiser</li> <li>● Mitsubishi L200, Pickup, Pajero</li> <li>● Nissan Pickup, Patrol</li> <li>● Volvo trucks</li> <li>● Ford Transit &amp; Utes</li> <li>● VW Utes</li> <li>● IVECO Utes &amp; trucks</li> <li>● Renault trucks</li> <li>● FIAT Utes</li> </ul>



To set up a quotation we require information regarding vehicle, type, engine and gearbox and system requirements.

All prices net, excl. VAT - General terms and conditions of business apply

**power-trax.de**

Special Duty Vehicles - technical Distribution